



BEWIS



AgileLight-300A series

Digital Closed Loop Single Axis Fibre Optic Gyroscope

Technical Manual



BEWIS

AgileLight-300A

Digital Closed Loop Single Axis Fibre Optic Gyroscope



Introduction

As an interference type digital closed-loop single-axis fiber optic gyroscope, AgileLight-300A has the advantages of low cost, large working bandwidth, high resolution, small zero drift, high linearity, short starting time, impact resistance and vibration resistance, it is an alternative to traditional mechanical gyros.

AgileLight-300A fiber optic gyroscope adopts IntelliProcess technology, which not only greatly eliminates the influence of temperature change on gyroscope performance, but also improves the key indicators of fiber optic gyroscope such as zero bias stability, angular random walk, scale factor linearity and stability. With low bias stability and angular random walk and strong vibration resistance, it is suitable for a variety of industrial applications. The high performance, rugged adaptability, compact construction and competitive price of the AgileLight-300A make it the recommended choice for motion sensing, platform stabilization, navigation and precision targeting.

Features

- All fiber optic technology: Long life, small size, high stability, anti-interference angle sensor.
- IntelliProcess Technology: Built-in high-performance digital signal processing chip for full digital operation and adaptive filtering technology makes the gyro's zero drift and angular velocity random walk 50%-75% lower than similar products.
- Integrated fiber polarization technology: reduces insertion loss, increases extinction ratio, and provides better resistance to temperature, mechanical shock and vibration for optical paths
- Compact and highly stable package: adapt to a variety of harsh environments. Widely applicable to all kinds of civil and military occasions
- QuickLaunch technology: Realize instant start-up, No external calibration required
- Optimal operating wavelength: sensitivity is increased by nearly 50% with the same structure, size and cost.
- Noise isolation and compression techniques: significantly reduce the angular velocity random walk
- SelfTrack technology: increase the dynamic range of the gyroscope

**Applications**

- Motion attitude control
- Servo tracking
- Damping of high speed train swing
- Antenna/Radar/optical platform stabilization
- Monitoring structural deformation
- Inertial north seeking
- Automatic goods trolley
- Robot balance
- Guidance and navigation
- Locking of the aiming system
- Oil drilling
- Miniature IMU, INS

Details**Performance Objective**

	Axis	Single axis
Technical Parameter	Measuring range (°/s)	-450~450
	Bias stability (°/h) , 1σ	≤0.1
	Bias repeatability (°/h) , 1σ	≤0.1
	Random walk coefficient (°/√hr)	≤0.01
	Scale factor nonlinearity (ppm)	≤200
	Scale factor asymmetry (ppm)	≤200
	Scale factor repeatability (ppm) , 1σ	≤200
	Physical Characteristics	Frequency bandwidth (Hz)
Start-up time (s)		≤1
Power Supply (V)		-5~+5
Power consumption (W)		≤5
Size(mm)		Φ70×H32
Weight (g)		≤220
Output mode		RS 422
Working temperature (°C)		-40~+65
Storage temperature (°C)		-45~+85
Connector		J30J-15TJL



Mechanical Characteristic

● **Gyroscope polar >**

The polarity of X, Y, and Z gyros is defined by the right-hand helix rule, and the three axes are orthogonal. The thumb represents the direction of the sensitive axis, and the other fingers represent the direction of the angular velocity.

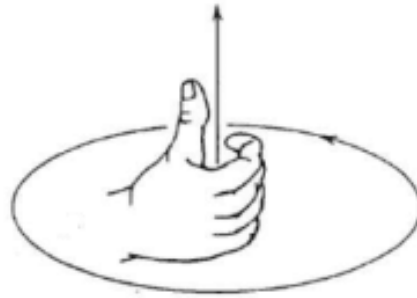
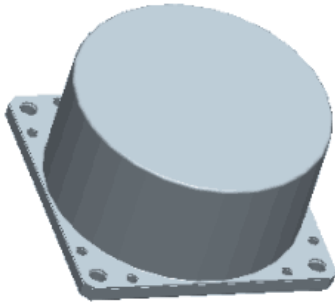

● **Working power supply >**

±5V power supply, power supply accuracy 5%, power supply ripple is not more than 20mV. The maximum inrush current of the full-temperature power supply is 1.2A. The steady-state power consumption at room temperature is ≤ 2.5W, and the full-temperature steady-state power consumption is ≤ 3.5W.

● **Electrical interface type >**

RS-422 digital serial port, adopt asynchronous serial standard duplex RS-422 electrical interface standard

● **Definition of output interfaces >**

The gyroscope use J30J-15TJL connector, the definitions of the nodes are seen in Table 1.

Node number	Definition	Node number	Definition
1	+5V	5	±5VGND
2	+5V	6	±5VGND
3	-5V	7	T+
4	-5V	8	T-
9-15	Disable		

Table 1: definition of J30J-15TJL



BEWIS

AgileLight-300A

Digital Closed Loop Single Axis Fibre Optic Gyroscope



Package size

Product Size: $\Phi 70 \times H32$ (mm)

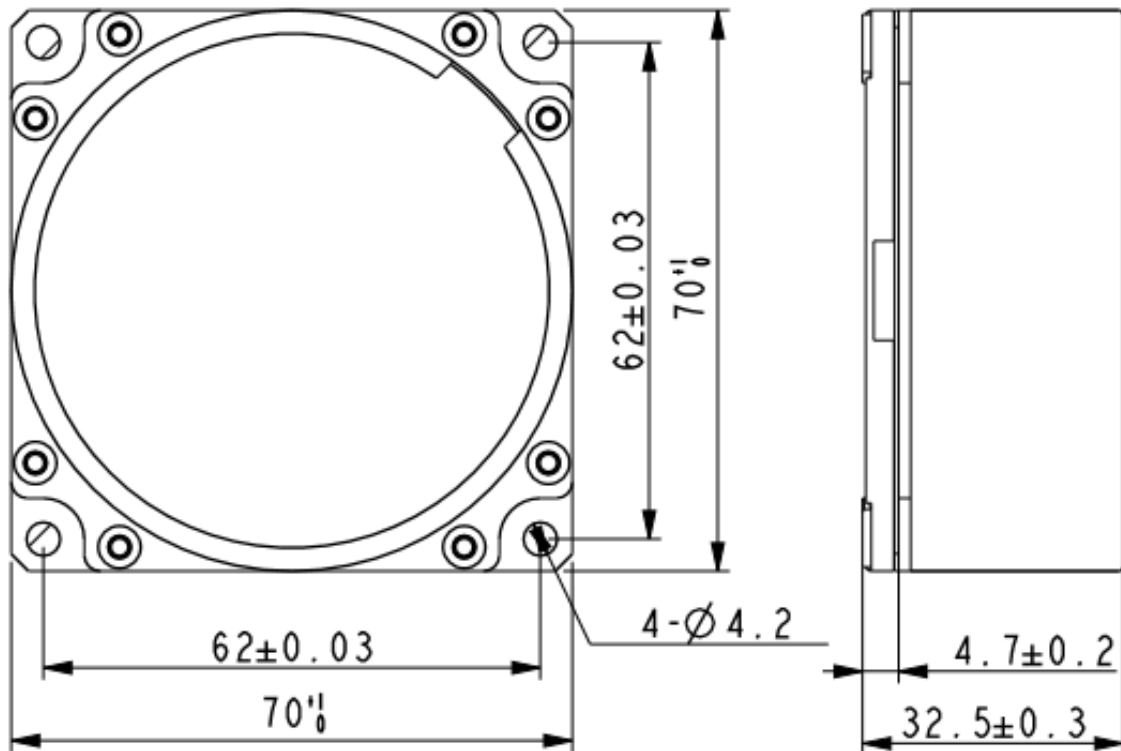

**Protocol**

- Baud rate: 115.200kbps ;
- Communication frame format , each frame contains 11 bits, the order is:
 - 1 bit for stat bit
 - 8 bits for data bit(send low bit first before the high bit)
 - 1 bit for parity check
 - 1 bit for stop bit
- Communication rule

The gyroscope uses broadcast communication, the data update for 2ms, the data frame formats are shown in Table 2.

Bits	Definition	Bit 7	6	5	4	3	2	1	Bit 0
1	Header	1	0	0	0	0	0	0	0
2	High 8 bits	0	D27	D26	D25	D24	D23	D22	D21
3	Middle 8 bits	0	D20	D19	D18	D17	D16	D15	D14
4	Middle 8 bits	0	D13	D12	D11	D10	D9	D8	D7
5	Low 8 bits	0	D6	D5	D4	D3	D2	D1	D0
6	Frame check	2 to 5 bytes bit by bit XOR							
7	High Temp	0	T13~T7						
8	Low Temp	0	T6~T0						

Table 2: Frame format of output data

- The three-byte angular rate data is in the complement format, and the angular rate conversion dimension is 30000 LSB/[o/s] (or see the product certificate). See Table 3 for conversion examples.



2ndbyte	3rdbyte	4thbyte	5thbyte	Decimal	Angular rate(°/s)
04H	25H	28H	40H	9000000	$9000000/30000 = 300.00000^\circ/s$
00H	01H	6AH	30H	30000	$30000/30000 = 1.00000^\circ/s$
00H	00H	00H	01H	1	$1/30000 = 0.00013^\circ/s$
7FH	7FH	7FH	7FH	-1	$-1/30000 = 0.00013^\circ/s$
7FH	7EH	15H	50H	-30000	$-30000/30000 = -1.00000^\circ/s$
7BH	5AH	57H	40H	-9000000	$-9000000/30000 = -300.00000^\circ/s$

Table 3: Example of angular rate conversion (scale factor 30000 LSB/[o/s])

Executive standard

- Enterprise Quality System Standard: ISO9001:2008 Standard (Certificate No.:10114Q16846ROS)
- CE certification (certificate number: 3854210814)
- ROHS (certificate number: SO81426003)
- GJB 2426A-2004 Fiber Optic Gyro Test Method
- GBT 18459-2001 sensor main static performance index calculation method
- JF 1059-1999 Evaluation and Expression of Measurement Uncertainty
- GBT 14412-2005 mechanical vibration and shock mechanical installation of accelerometer
- General requirements for GJB 450A-2004 equipment reliability
- Quality control of key parts and important parts of GJB 909A
- GJB 899 Reliability Qualification and Acceptance Test
- GJB 150-3A high temperature test
- GJB 150-4A low temperature test
- GJB 150-8A rain test
- GJB 150-12A dust test
- GJB 150-16A vibration test
- GJB 150-18A impact test
- GJB 150-23A Tilt and Swing Test
- GB/T 17626-3A RF electromagnetic radiation immunity test
- GB/T 17626-5A surge (hit) impulse immunity test
- GB/T 17626-8A power frequency magnetic field immunity test
- GB/T 17626-11A voltage dips, short interruptions and voltage changes immunity

AgileLight-300A

Digital Closed Loop Single
Axis Fibre Optic Gyroscope

Wuxi Bewis Sensing Technology LLC

Address: Building 30, No. 58 Xiuxi Road, Binhu
District, Wuxi City

Hotline: 400-618-0510

Tel: +86 510 85737158

Email: sales@bwsensing.com

Website: www.bwsensing.com