



BWM426S Series

**Digital Dual Axis
Inclinometer**

Technical Manual



Introduction

BWM426S is a cost-effective dual-axis inclinometer developed and produced by Bewis Sensing, which adopts MEMS technology and digital output. It has a measurement range of $\pm 90^\circ$, the highest accuracy of 0.01° , and an operating temperature of -40°C to $+85^\circ\text{C}$. The product uses a high-precision MEMS accelerometer and a high-resolution differential digital-to-analog converter, with built-in automatic compensation and filtering algorithms, which eliminates errors caused by environmental changes to the greatest extent. Convert the change of the static gravity field into the change of the inclination angle, and directly output the horizontal inclination value through the digital method. This product has high long-term stability, low temperature drift, simple use, and strong ability to resist external interference. It is used for surveying and mapping, industrial automation and other industries. Recommended choice!

Main Feature

- Dual axis inclination measurement
- Resolution: 0.001°
- Power supply: 9-35V
- Dimension: L55*W37*H24 (mm)
- Highest accuracy: 0.01°
- Range: $\pm 90^\circ$
- Output: RS232/RS485/TTL optional
- IP67 Protection level

Application

- Industrial automatic leveling
- Medical instruments
- Photovoltaic automatic tracking
- Tower tilt monitoring
- Structural deformation monitoring
- Surveying and Mapping Instruments
- Equipment automation
- Lifting equipment inclination control

Electrical Index

Parameter	Condition	Minimum	Typical	Maximum
Power voltage(V)		9	12	35
Working Current (mA)	No load	20	30	40
Operating Temperature (°C)		-40	25	85
Storage Temperature (°C)		-55	25	100

Performance Index

Measurement Range (°)	Condition	±90
Measurement axis		X-Y
Accuracy (°)	Room temperature	0.01
Resolution (°)	Completely still	0.001
Zero bias (°/°C)	-40~85°C	±0.005
Start-up time		< 3s
Output frequency (Hz)	5-100Hz adjustable	Up to 100
Mean time between failures MTBF	≥90000h	
Electromagnetic compatibility	According to GBT17626	
Insulation resistance	≥100 MΩ	
Impact resistance	2000g, 0.5ms, 3 times/axis	

Resolution: The smallest change value of the measured value that the sensor can detect and distinguish within the measurement range.

Accuracy: The root mean square error of the actual angle and the sensor measuring angle for multiple (≥16 times) measurements.



Mechanical Index

Connector	Metal Joint (Cable 1.5m)
Protection level	IP67
Shell material	Magnesium aluminum alloy oxidation
Installation	Three M4 screws



Package product size

Product size: L55*W37*H24 (mm)

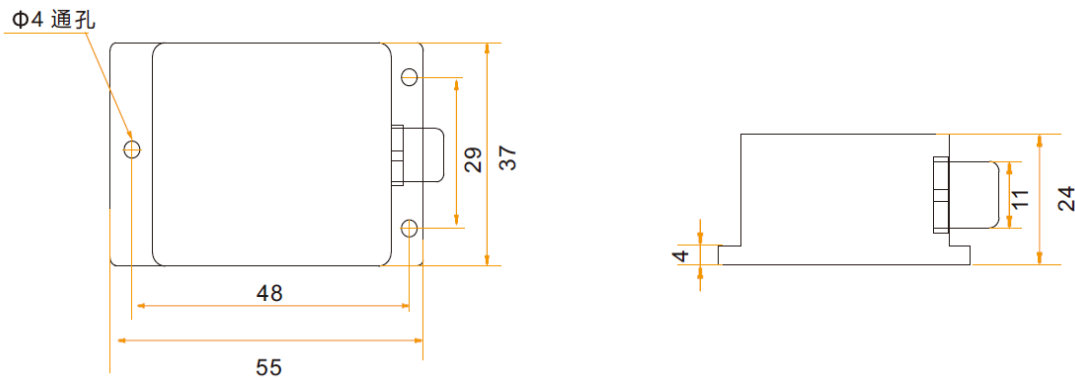

Bara board product size

Product size: L33*W27*H6(mm), The length and width may have an error of ± 1 mm, please refer to the actual product

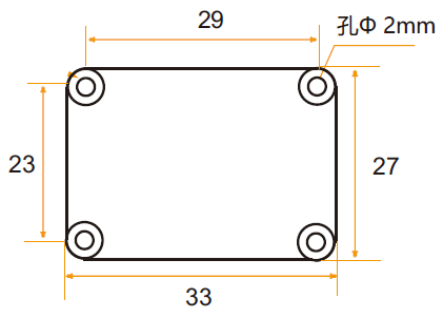

Installation

The correct installation method can avoid measurement errors. When installing the sensor, please do the following:

First of all, make sure that the sensor mounting surface is completely close to the measured surface, and the measured surface should be as level as possible, and there should be no included angles as shown in Figure A and Figure C. The correct installation method is shown in Figure B and Figure D.

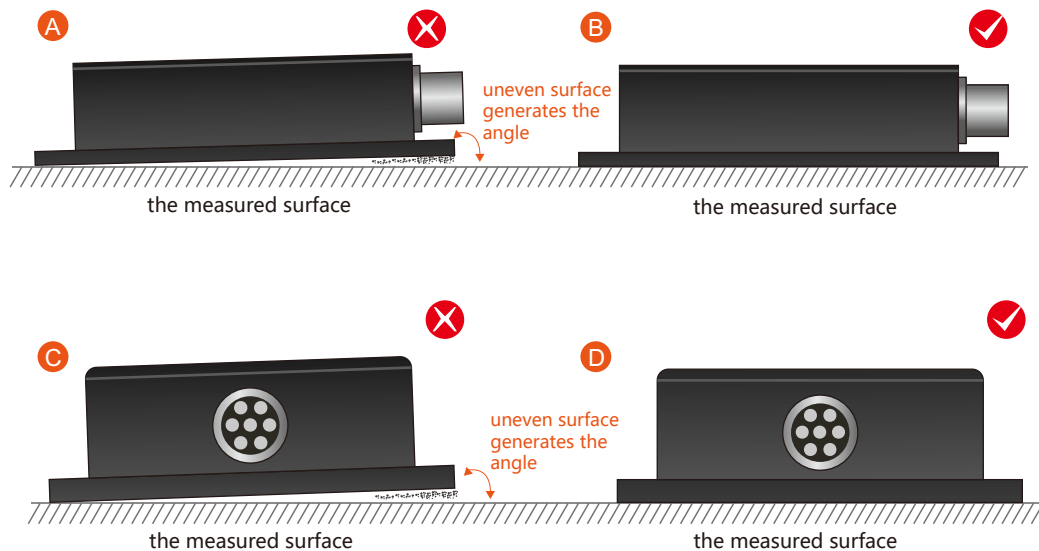

Secondly, the bottom line of the sensor and the axis of the measured object cannot have an angle as shown in Figure E, and the bottom line of the sensor should be kept parallel or orthogonal to the axis of rotation of the measured object during installation. This product can be installed horizontally or vertically (vertical installation needs to be customized), and the correct installation method is shown in Figure F.

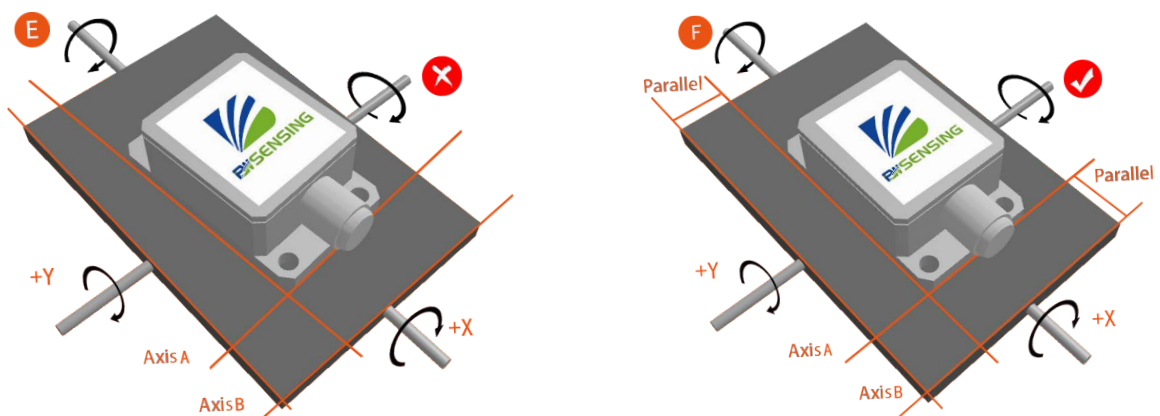

Finally, the mounting surface of the sensor and the surface to be measured must be tightly fixed, smooth in contact, and stable in rotation, and measurement errors due to acceleration and vibration must be avoided.

Electrical Interface

Wiring Definition

	RED	BLUE	BLACK	GREEN	YELLOW
Wire color	1	2	3	4	5
function	VCC DC 9-35V	NC	GND ground	Receive RXD (B、D-)	Send TXD (A、D+)

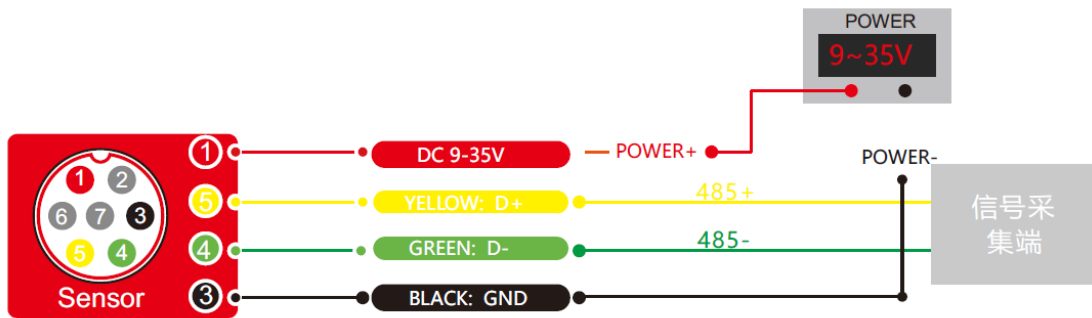

Wiring definition

	RED	BLUE	BLACK	GREEN	YELLOW
Wire color	1	2	3	4	5
function	VCC DC 9-35V	NC	GND ground	B、D-	A、D+

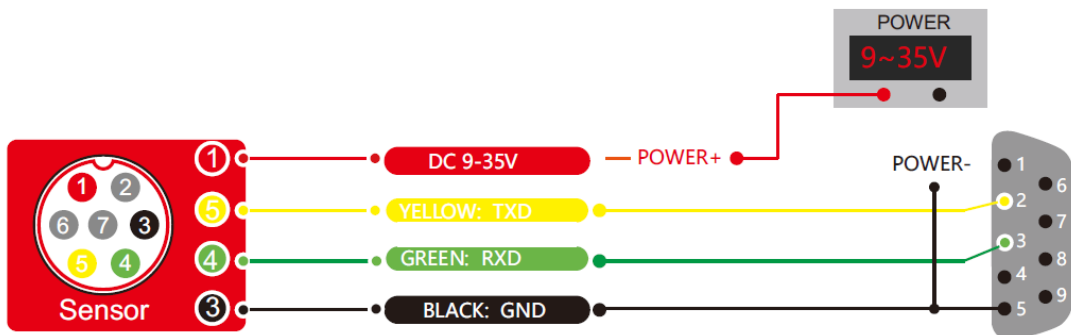

Debugging software

You can download the serial debugging assistant directly on the official website (technical service -> download area), or you can use the more convenient and intuitive host computer software.

BWM426S supporting serial port debugging software can connect the inclination sensor on the computer to display the angle. The software debugging interface is shown in the figure below. Using the tilt angle to debug the host computer, you can conveniently display the current X direction and Y direction tilt angle, and you can also modify and set other parameters.

Step:

- ① Connect the serial port hardware of the inclinometer correctly, and connect the power supply.
- ② Select computer serial port and baud rate and click connect serial port.
- ③ Click start button and the current inclination Angle of the incliner in X and Y directions will be displayed on the screen.

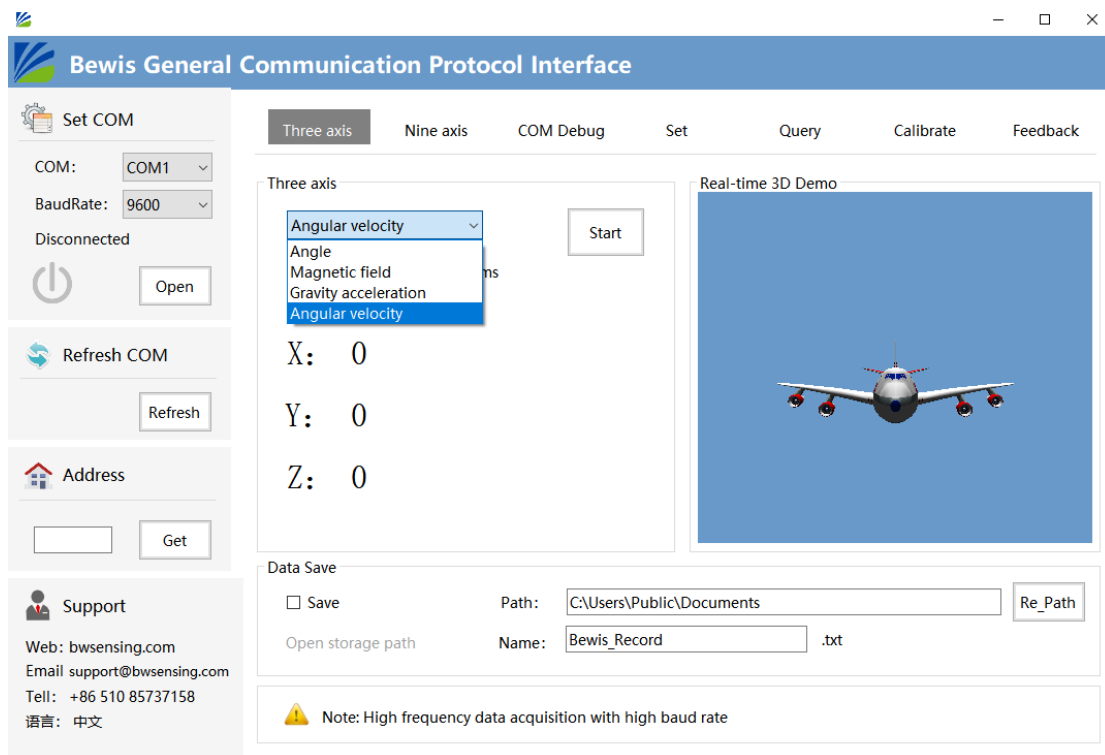

Order information

Model	Communication code	Package situation
BWM426S-90-485	RS485	IP67 Package/Metal joint
BWM426S-90-232	RS232	IP67 Package/Metal joint
BWM426S-90-TTL	TTL	IP67 Package/Metal joint

Executive standard

- Enterprise Quality System Standard: ISO9001:2015 Standard (Certificate No.064-21-Q-3290-RO-S)
- CE certification (certificate number: M.2019.103. U Y1151)
- ROHS (certificate Number: G 190930099)
- GB/T 191 SJ 20873-2003 General specification for inclinometer and level
- GBT 18459-2001 The calculation method of the main static performance index of the sensor
- JJF 1059.1-2012 Evaluation and expression of measurement uncertainty
- GBT 14412-2005 Mechanical vibration and shock Mechanical installation of accelerometer
- GJB 450A-2004 General requirements for equipment reliability
- GJB 909A Quality control of key parts and important parts
- GJB899 Reliability appraisal and acceptance test
- GJB150-3A High temperature test
- GJB150-4A Low temperature test
- GJB150-8A Rain test
- GJB150-12A Sand and dust experiment
- GJB150-16A Vibration test
- GJB150-18A Impact test
- GJB150-23A Tilt and rock test
- GB/T 17626-3A Radio frequency electromagnetic field radiation immunity test
- GB/T 17626-5A Surge (impact) immunity test
- GB/T 17626-8A Power frequency magnetic field immunity test
- GB/T 17626-11A Immunity to voltage dips, short-term interruptions and voltage changes

BWM426S Series

Digital Dual Axis Inclinometer

Wuxi Bewis Sensing Technology LLC

Add: Building 30, NO. 58, Xiuxi Road, Binhu District,
Wuxi City, Jiangsu Province, China

Tel: +86 18921292620

Mail: sales@bwsensing.com

Web: www.bwsensing.com