

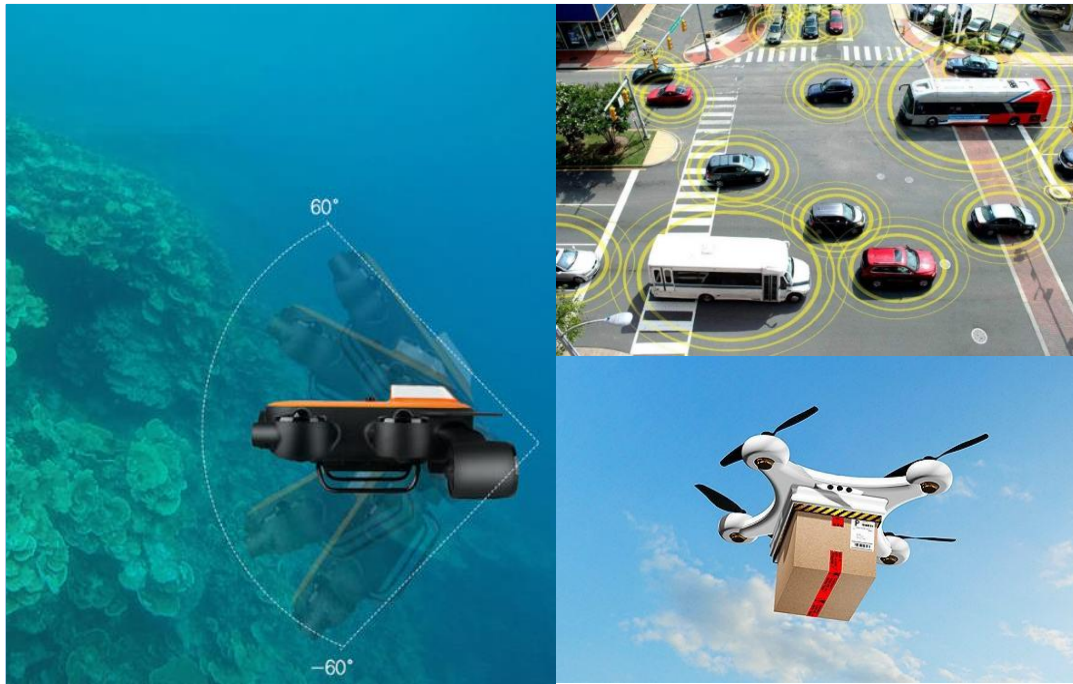

# **BW-IMU710 Series**

## **Small-size three-axis fiber optic gyroscope inertial measurement unit**

# **Technical Manual**



### Introduction

BW-IMU710 is a small-size high-precision three-axis fiber optic gyroscope inertial measurement unit developed and produced by Bewis Sensing. It can output acceleration and angular velocity information without relying on external signal input, which can be calculated through user-developed algorithms. The azimuth angle, roll angle, pitch angle, Euler angle, and quaternion information of the measured carrier are suitable for inertial attitude measurement under various states of motion, vibration or static.

BW-IMU710 has a built-in three-axis fiber optic gyroscope and a highly reliable MEMS accelerometer. The original data deviation is estimated by the 6-state Kalman filter with appropriate gain, and the measurement accuracy is guaranteed by the algorithm, and the nonlinear compensation, quadrature compensation, Temperature compensation and drift compensation, etc., are used to greatly eliminate errors and improve product accuracy. This product has a digital interface, which can be easily integrated into the system.

### Feature

- Gyro bias stability:  $\leq 0.3^\circ/h$
- Accelerometer bias stability: 0.5mg
- Gyro scale factor:  $\leq 100ppm$
- Accelerometer range:  $\pm 30g$
- Output mode: RS422
- Working temperature:  $-40^\circ C \sim +60^\circ C$
- Weight(without package):  $\leq 450g$
- Small size: L70×W65×H51mm

### Application

- Unmanned boats and underwater vehicles
- Special robots
- Marine engineering surveying and mapping
- Unmanned vehicles and autonomous Driving
- Attitude measurement and maintenance
- Unmanned aircraft

### Specification



#### Electrical index

Power supply	9-30V DC
Power ripple	≤50mV
Operating temperature	-40~60°C
Storage temperature	-55~80°C



#### Performance index

Fiber optic gyroscope	Bias stability	≤0.3°/h (10s,1σ)
	ARW	≤0.03 °/√h
	Bias repeatability	≤0.3°/h (1σ)
	Bias stability at full temperature	≤0.3°/h (100s, 1σ)
	Scale factor nonlinearity	≤100ppm (1σ)
	Scale factor repeatability	≤100ppm (1σ)
	Bandwidth	≥400Hz
	Measurement range	-800~+800°/s
	Random walk coefficient	≤0.03 °/√h
Accelerometer	Range: X, Y, Z	±30 g
	Bias stability at room temperature	0.3mg (10s,1σ)
	Bias stability at full temperature	0.6mg (10s,1σ)
	Scale factor nonlinearity	300ppm (1σ)
	Scale factor repeatability	300ppm (1σ)
Other index	Dimension	70×65×51mm
	Start-up time	≤1min
	Weight	≤450g

### Mechanical properties

Connector	RS422 communication, J63A-242-015-261-TH
Protection level	IP63(IP67 customized)
Shell material	Magnesium aluminum alloy anodizing
Installation	Four M4 screws

### Package product size

Product size: L70\*W65\*H51 (mm)

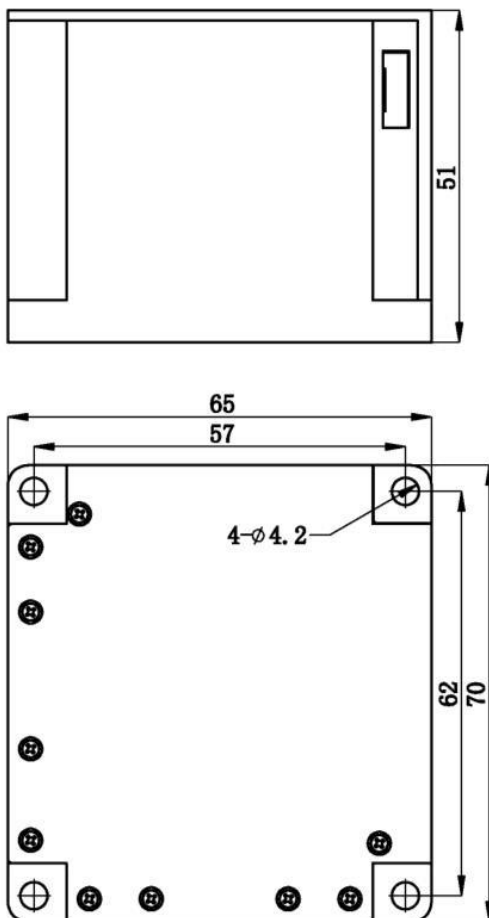

### Installation

The user is responsible for the installation and disassembly of the product. During this process, the product cannot be hit, and the outer surface of the product cannot be mechanically processed.

The correct installation method can avoid measurement errors. When installing the sensor, please do the following:

First of all, ensure that the sensor mounting surface is completely close to the surface to be measured. The surface to be measured should be as level as possible, and there should be no included angles as shown in Figure A and Figure C. The correct installation method is shown in Figure B and Figure D.

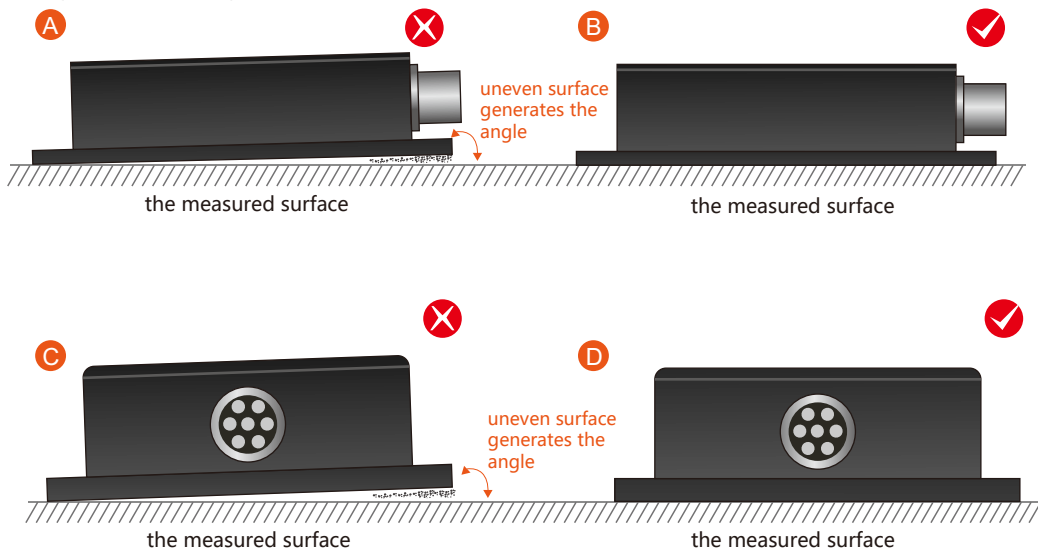

Secondly, the bottom line of the sensor and the axis of the measured object cannot have an angle as shown in Figure E. When installing, keep the bottom line of the sensor parallel or orthogonal to the axis of rotation of the measured object. This product can be installed horizontally or vertically (vertical installation needs to be customized), and the correct installation method is shown in Figure F.

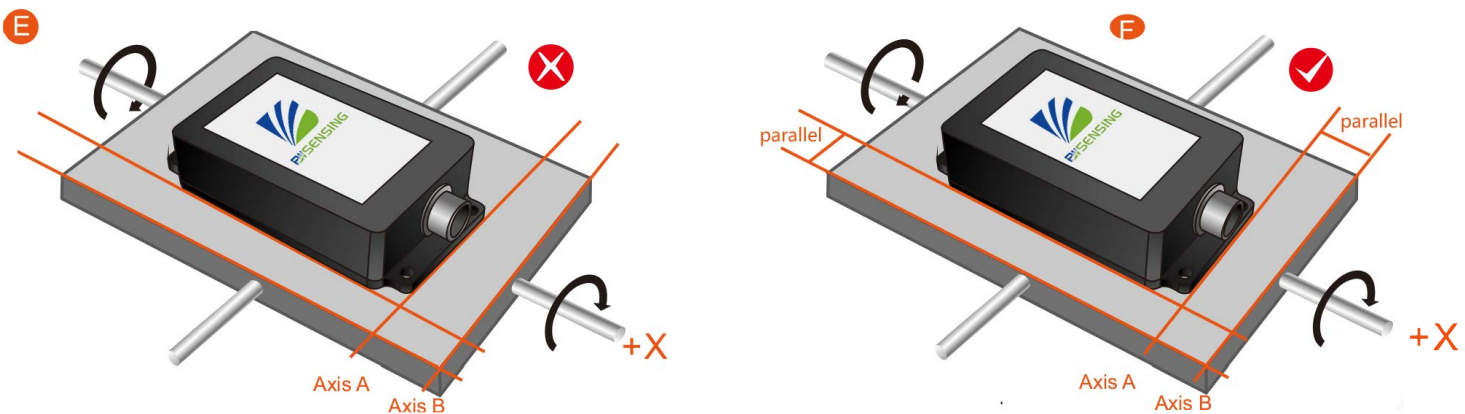

Finally, the mounting surface of the sensor and the surface to be measured must be tightly fixed, smooth in contact, and stable in rotation, and measurement errors due to acceleration and vibration must be avoided.

### Electrical connection

Core point No.	Definition	Annotation
1	GND_IN	Input
2	VIN	Power input
3	VCC_5V	+5V(0.5A) reserve output power
4	P_GND	Keep output
5	A422_R+	Serial port A inertial terminal receiving positive
6	A422_R-	Serial port A used to receive negative
7	A422_T-	Serial port A used to send negative
8	A422_T+	Serial port A habit group terminal sends positive
9	B422_R+	Serial port B inertial terminal receiving positive
10	B422_R-	Serial port B inertia terminal receives negative
11	B422_T+	Serial port B used to send negative
12	B422_T-	The serial port B is used to send positive
13	Hang in the air	
14	Hang in the air	
15	Hang in the air	

Note: When connecting or touching the product, anti-static measures should be taken in.

### Procedure

1. Check before use  
Check the appearance of the product for physical damage such as collisions.
2. Instructions on how to use the product
  - a) The product is installed on the carrier, and the cable is correctly connected as required;
  - b) Perform data connection in accordance with the communication protocol.
3. Matters needing attention
  - a) The product should not be frequently switched on and off during use, so as not to damage the performance of the gyro and reduce the service life of the product;
  - b) Before powering on the product, check the power supply system to ensure that there is no short circuit between the electrical points of the power supply, and between the product shell and the electrical points;
  - c) If there is any abnormal operation of this product, please consult the manufacturer and prohibit unauthorized disassembly and maintenance;
  - d) The optical fiber inertial unit is a precision instrument, which should be handled with care during use and transportation;;
  - e) Must ensure the correct connection of product input and output signal lines and power supply lines;
  - f) Anti-static measures are required to be taken during the contact with the product;
  - g) The magnetic field strength around the product location is required to be less than 2 Gauss.

### Protocol

- 1) Two-way communication, the request signal is 3.3V, LVTTTL level, the falling edge is valid (the falling edge represents the sampling time), the falling edge is input within 50us, and the serial port signal is sent, which conforms to the RS-422 interface standard;
- 2) Data refresh rate 200Hz, baud rate 460.8Kbps; (customizable)
- 3) 8 data bits, 1 stop bit, no parity bit;
- 4) Data transmission format:

Byte	Name	Value	Transmission	Type
0	Frame header byte 1	OxAA		uchar
1	Frame header byte 2	OxAA		uchar
2	Data sent count	1~200		uchar
3	Self-check byte	255		uchar
4~7	X-axis gyro	32bit low in the front, high in the back		signed int32
8~11	Y-axis gyro	32bit low in the front, high in the back		signed int32
12~15	Z-axis gyro	32bit low in the front, high in the back		signed int32
16~19	X-axis accelerometer	32bit low in the front, high in the back		float
20~23	Y-axis accelerometer	32bit low in the front, high in the back		float
24~27	Z-axis accelerometer	32bit low in the front, high in the back		float
28,29	X-axis gyro temperature	16bit low in the front, high in the back	1/16	signed int16
30,31	Y-axis gyro temperature	16bit low in the front, high in the back	1/16	signed int16
32,33	Z-axis gyro temperature	16bit low in the front, high in the back	1/16	signed int16
34,35	X-axis accelerometer temperature	16bit low in the front, high in the back	1/16	signed int16
36,37	Y-axis accelerometer temperature	16bit low in the front, high in the back	1/16	signed int16
38,39	Z-axis accelerometer temperature	16bit low in the front, high in the back	1/16	signed int16
40	Checksum	4~39 byte XOR		uchar
41	Frame end	OxBB		uchar

## Executive standard

- National Standard for Static Calibration Specifications for Dual-Axis Inclination Sensors (Draft)
- GB/T 191 SJ 20873-2003 General Specification for Inclinometers and Levels



# **BW-IMU710 Series**

**Small-size three-axis fiber optic  
inertial measurement unit**

## **Wuxi Bewis Sensing Technology LLC**

Add: Building 30, NO. 58, Xiuxi Road, Binhu District,

Wuxi City, Jiangsu Province, China

Tel: +86 18921292620

Mail: [sales@bwsensing.com](mailto:sales@bwsensing.com)

Web: [www.bwsensing.com](http://www.bwsensing.com)